

DATE	SYMBOL	REVISION RECORD	AUTH.	DR.	CK.
10/21/02	A	REVISED & REDRAWN			827

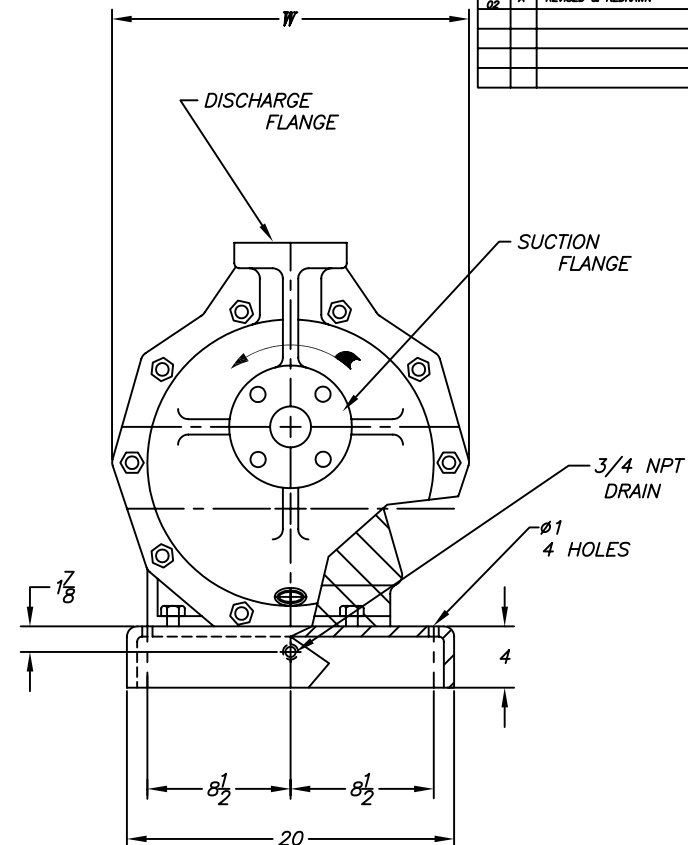
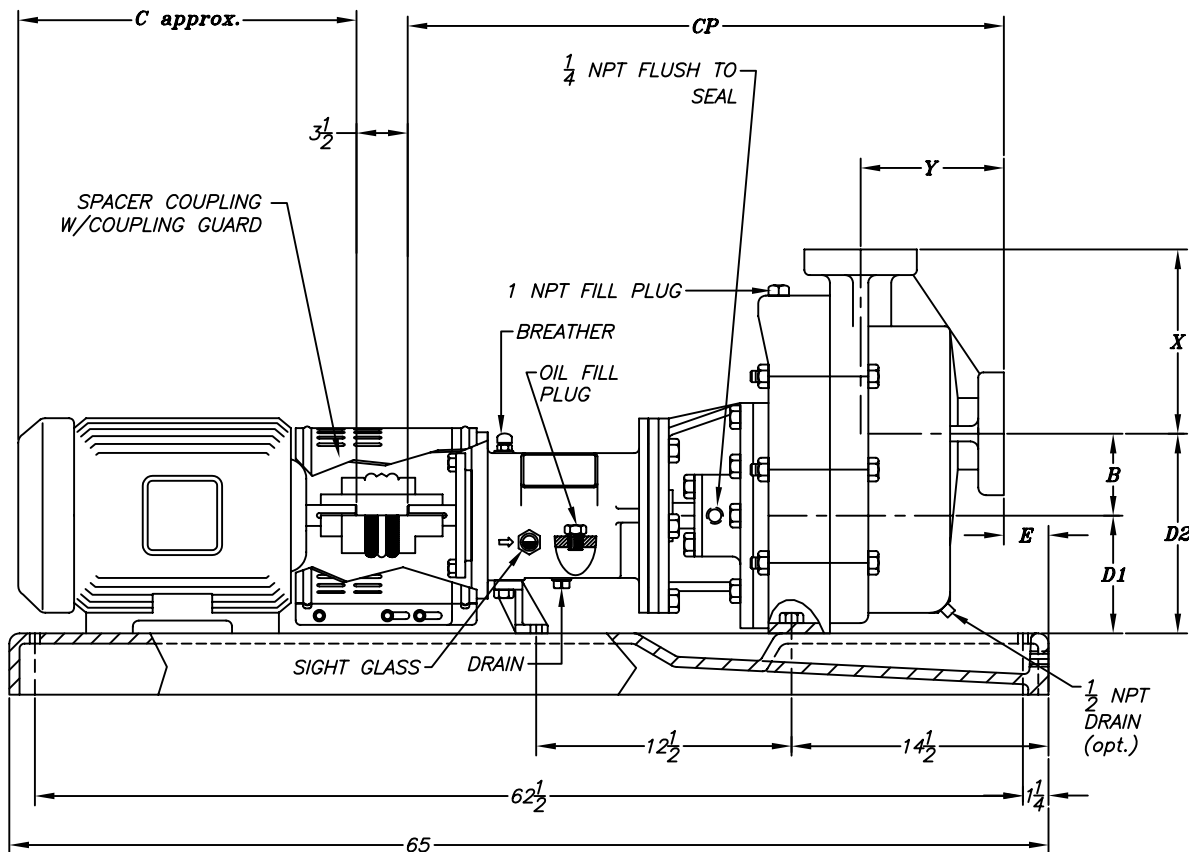

NOTES:  
 1. ALL DIMENSIONS IN INCHES  
 2. FLANGES ARE ASME/ANSI B16.5 CLASS 150lb. FLAT FACE.  
 3. ROTATION IS COUNTERCLOCKWISE FACING SUCTION FLANGE.  
**WARNING: DO NOT OPERATE WITHOUT LIQUID IN PUMP. DO NOT OPERATE IN REVERSE ROTATION.**

MOTOR FRAME	C
182T/184T	15 5/8
213T/215T	19 1/4
254T/256T	25 1/2
284T/286T	27 5/8
324T/326T	29 11/16
284TS/286TS	24 3/4
324TS/326TS	28 1/4

MOTOR		
HP	RPM	
PH	HZ	VOLTS
ENCL.		
FRAME		

FLANGE	O.D.	THICK.	B.C.	NO. OF HOLES	SZ. OF HOLES
2	6	1 1/8	4 3/4	4	3/4
3	7 1/2	1 3/16	6	4	3/4
4	9	1 3/8	7 1/2	8	3/4
6	11	1 9/16	9 1/2	8	7/8

PUMP SIZE	SUCT.	DISCH.	B	D1	D2	E	W	X	Y	CP
2X3X10	3	2	6	8 1/4	14 1/4	2 1/4	22 7/8	10 1/2	8 1/4	31 3/4
3X4X10	4	3	6	8 1/4	14 1/4	2 1/4	22 7/8	10 1/2	8 1/4	31 3/4
3X4X13	4	3	7	10	17	1 1/4	26 1/2	11 1/2	8 7/8	32 3/4
4X6X13	6	4	7	10	17	1/4	28 1/8	13	9	33 3/4

CUSTOMER		
CUST. P.O.#		
ITEM		
FYBROC S/N		
<b>Fybrec Division</b> TELFORD, PA 18969		
1600 SERIES GROUP 2	SCALE ~	DRAWN BY <i>ELJ</i>
TITLE		APPROVED BY
OUTLINE DRAWING		
DATE 6/16/94	DRAWING NUMBER <b>C40123</b>	REV. <b>A</b>